

=====
= SCHEMATIC DIAGRAMS =
= JOHANNUS =
= OPUS 250 =
= alterations reserved =

C O N T E N T S

1. POSITION DIAGRAM
2. POWER SUPPLY
3. SWITCH-SECTION PRESETS; HICK CIRCUIT; TREMULANT CIRCUIT;
EXPRESSION PEDAL CIRCUIT; CHORUS & VOLUME
4. COUPLER CIRCUIT
5. SWITCH-SECTION TRANSPOSER & GENERATOR/TRANSPOSER PEDAL
6. KEYING PEDAL
7. PRE-AMP'S PEDAL
8. VOICES PEDAL
9. GENERATORS/TRANSPOSERS MANUALS (1x GREAT & 1x SWELL)
10. KEYING GREAT
11. PRE-AMP'S GREAT
12. VOICES GREAT
13. KEYING SWELL
14. PRE-AMP'S SWELL
15. VOICES SWELL
16. INPUT/OUTPUT CIRCUIT ECHO UNIT
17. DELAY LINE ECHO UNIT
18. VOICE AMPLIFIERS
19. POWER-AMPLIFIER (3x)
20. LOUDSPEAKER- & HEADPHONES-CIRCUIT
21. GENERAL INFORMATION SEMI-CONDUCTORS

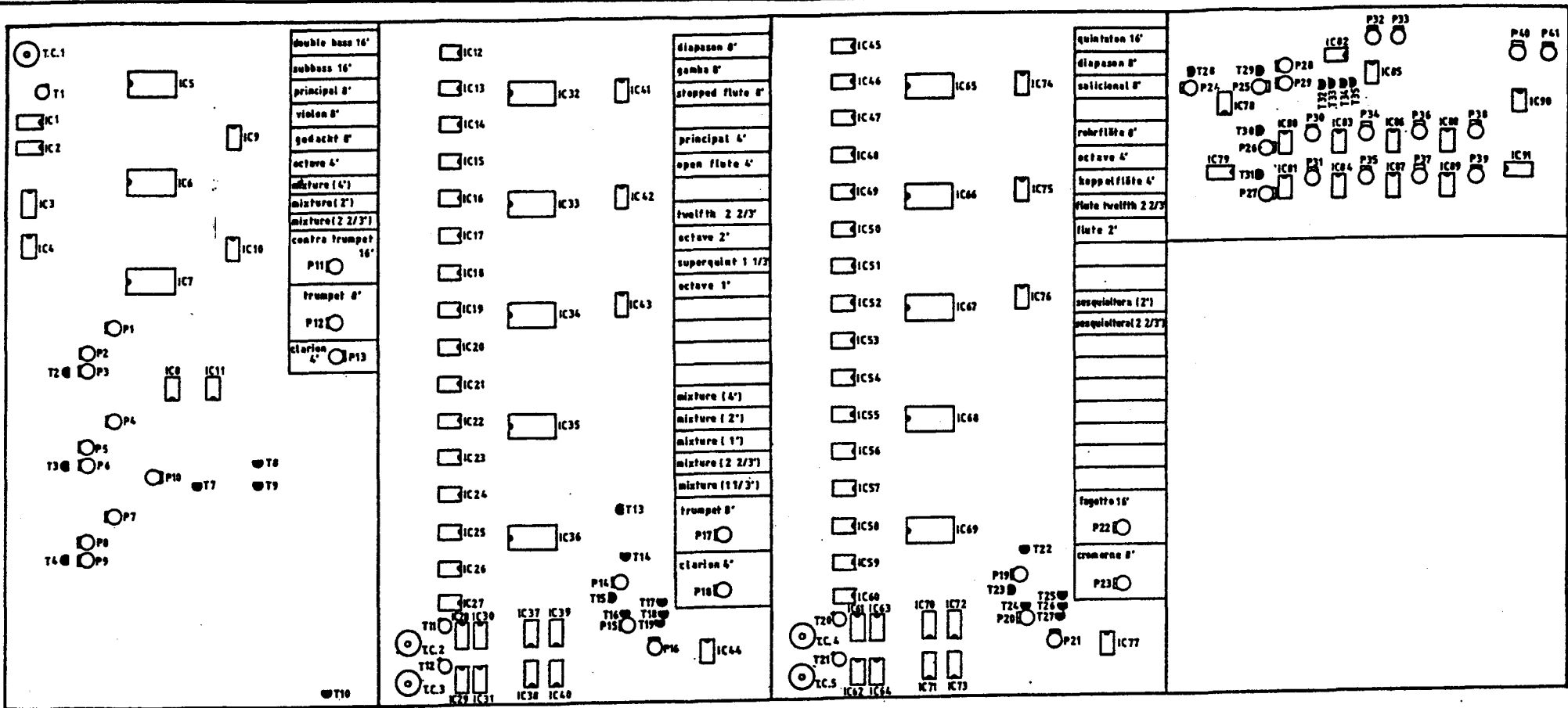

P1: volume treble amplifier
 P2: bass adjustment treble amplifier
 P3: treble adjustment treble amplifier
 P4: volume middle amplifier
 P5: bass adjustment middle amplifier
 P6: treble adjustment middle amplifier
 P7: volume bass amplifier
 P8: bass adjustment bass amplifier
 P9: treble adjustment bass amplifier
 P10: linearity expression pedal
 P11: volume contra trumpet 16' pedal
 P12: volume trumpet 8' pedal
 P13: volume clarion 4' pedal
 P14: tremulant speed great
 P15: hick depth great
 P16: tremulant depth great
 P17: volume trumpet 8' great
 P18: volume clarion 4' great
 P19: tremulant speed swell
 P20: hick depth swell
 P21: tremulant depth swell
 P22: volume fagotto 16' swell
 P23: volume cromorne 8' swell

P24: amplitude output channel A echo unit.
 P25: amplitude output channel B echo unit
 P26: clockripple elimination delay line echo unit channel B
 P27: clockripple elimination delay line echo unit channel A
 P28: amplitude feed-back signal channel A to channel B
 P29: amplitude feed-back signal channel B to channel A
 P30: DC-offset IC 80
 P31: DC-offset IC 81
 P32: clock frequency
 P33: amplitude chorus
 P34: DC-offset IC 83
 P35: DC-offset IC 84
 P36: DC-offset IC 86
 P37: DC-offset IC 87
 P38: DC-offset IC 88
 P39: DC-offset IC 89
 P40: amplitude input channel B echo unit
 P41: amplitude input channel A echo unit

 T.C.1: tuning pedal
 T.C.2: tuning 2nd; 4th & 5th octave great
 T.C.3: tuning 1st & 3rd octave great
 T.C.4: tuning 2nd & 4th octave swell
 T.C.5: tuning 1st; 3rd & 5th octave swell

IC 1; 28; 29; 61; 62.....MO 83
 IC 2; 30; 31; 63; 64.....4512
 IC 3; 37; 38; 70; 71.....4046
 IC 4; 39; 40; 72; 73.....4520
 IC 5-7; 32-36; 65-69.....TMS 3617
 IC 8-11; 41-44; 74-78; 90.....TL 074
 IC 12-27; 45-59.....LM 339
 IC 79; 91.....NE 570
 IC 80; 81; 83; 84; 86-89.....TDA 2108
 IC 82.....4093
 IC 85.....LM 324

 T 1; 11; 12; 20; 21.....BC 141
 T 2-7; 10; 13-19; 22-31; 33; 34....BC 549
 T 8; 9.....BC 337
 T 32; 35.....BC 558

T5 & T6 ARE DISPOSED

POSITION DIAGRAM				JOHANNUS ORGAN OPUS 250
Drawn	Date	Modified	Date	
Verschoor	28-04-86			
DESIGN				
LAB.				
copyright: ELECTRONUM B.V.	JOHANNUS ORGELBOUW b.v.	morsestraat 28 6716 AH EDE HOLLAND Tel. 08380-37403	page: 1	

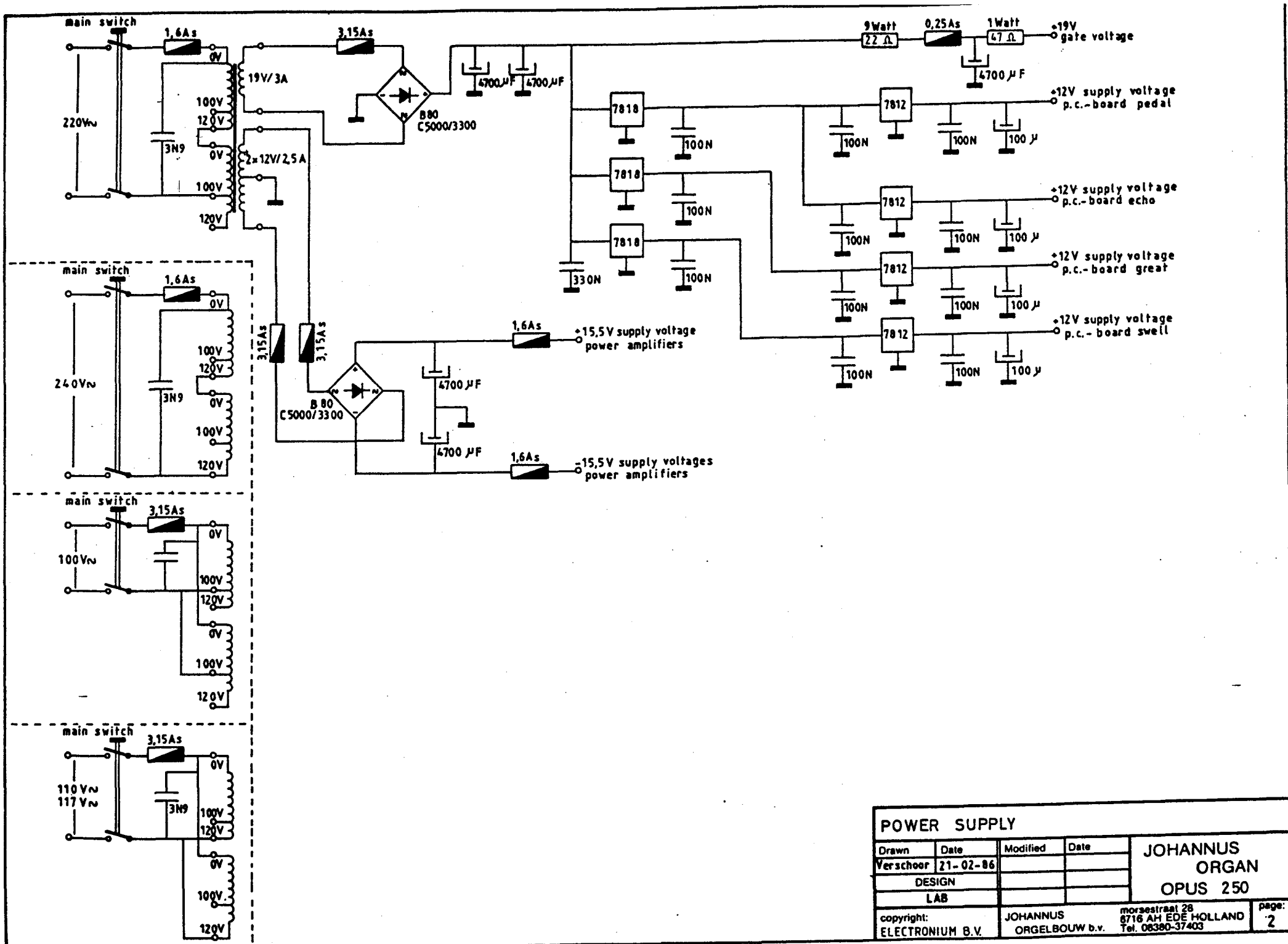

POWER SUPPLY				JOHANNUS ORGAN OPUS 250
Drawn	Date	Modified	Date	
Verschoor	21-02-86			
DESIGN				
LAB				
copyright:	JOHANNUS	morsestraat 28		page:
ELECTRONIUM B.V.	ORGELBOUW b.v.	6716 AH EDE HOLLAND		2
		Tel. 06380-37403		

SWITCH-SECTION PRESETS

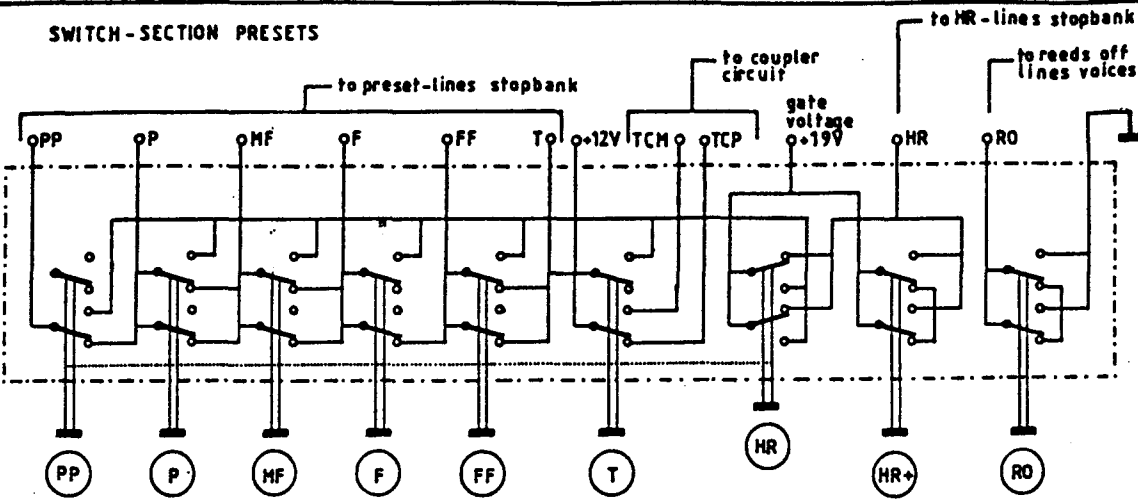

EXPRESSION PEDAL CIRCUIT

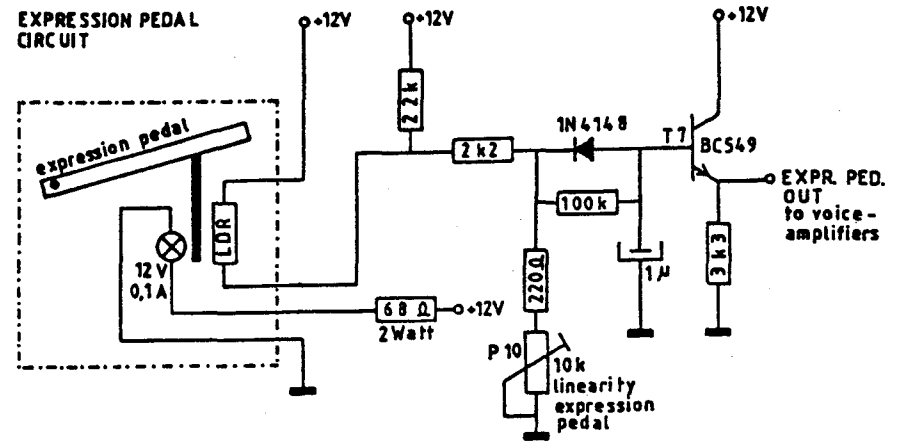

HICK CIRCUIT 2x
1x great (T15;T16;P15)
1xswell (T23;T24;P20)

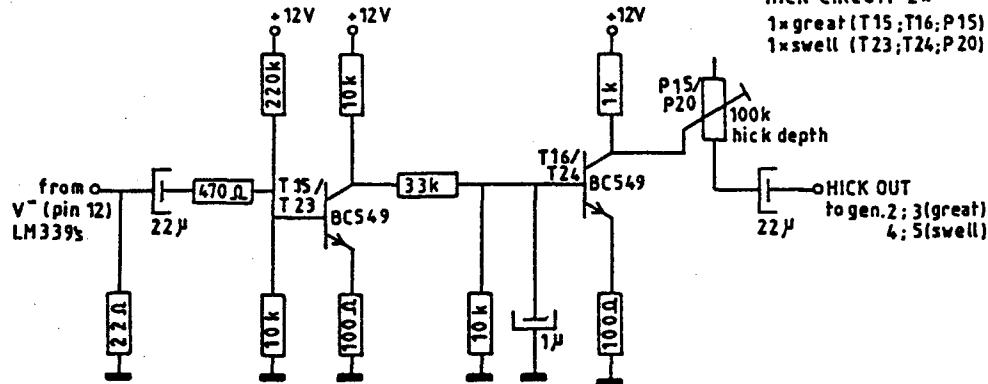

CHORUS

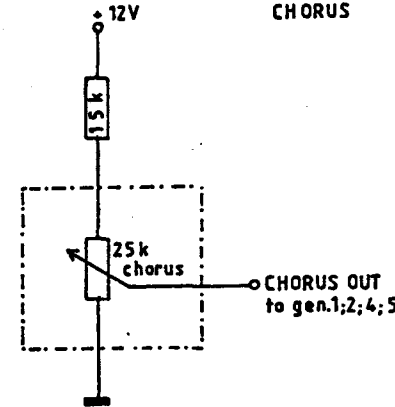

VOLUME

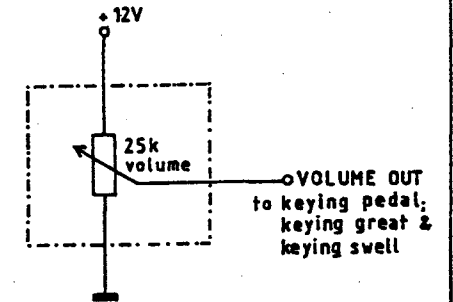

TREMULANT CIRCUIT 2x:
1x great (T14;T17;T18;T19;P14;P16)
1xswell (T22;T25;T26;T27;P19;P21)

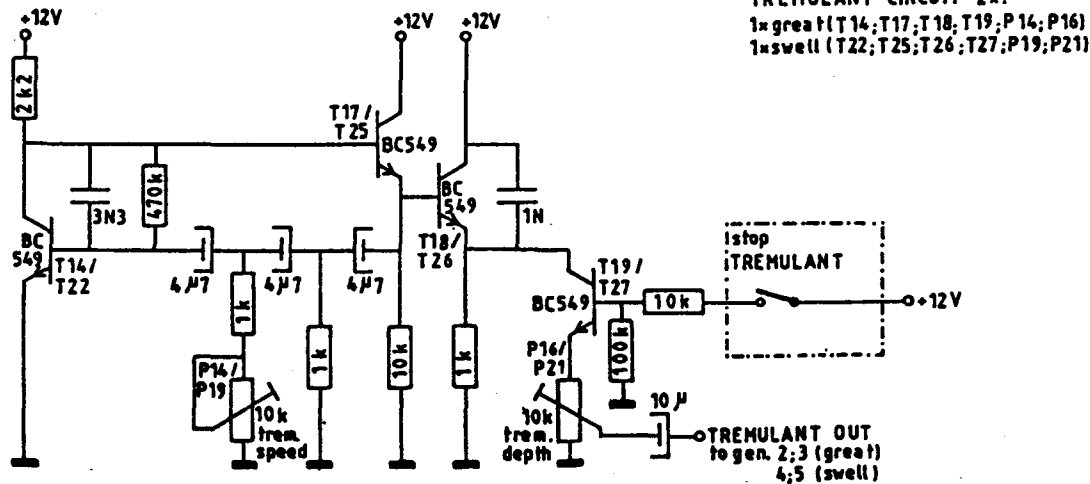

SWITCH - SECTION

PRESETS ; HICK CIRCUIT ; TREMULANT CIRCUIT ;

EXPRESSION PEDAL CIRCUIT ; CHORUS & VOLUME

Drawn	Date	Modified	Date	JOHANNUS ORGAN OPUS 250
Verschuur	03-04-86			
DESIGN				
LAB.				
copyright: ELECTRONIUM B.V.	JOHANNUS ORGELBOUW b.v.	morsestraat 28 6716 AH EDE HOLLAND Tel. 08380-37403	page: 3	

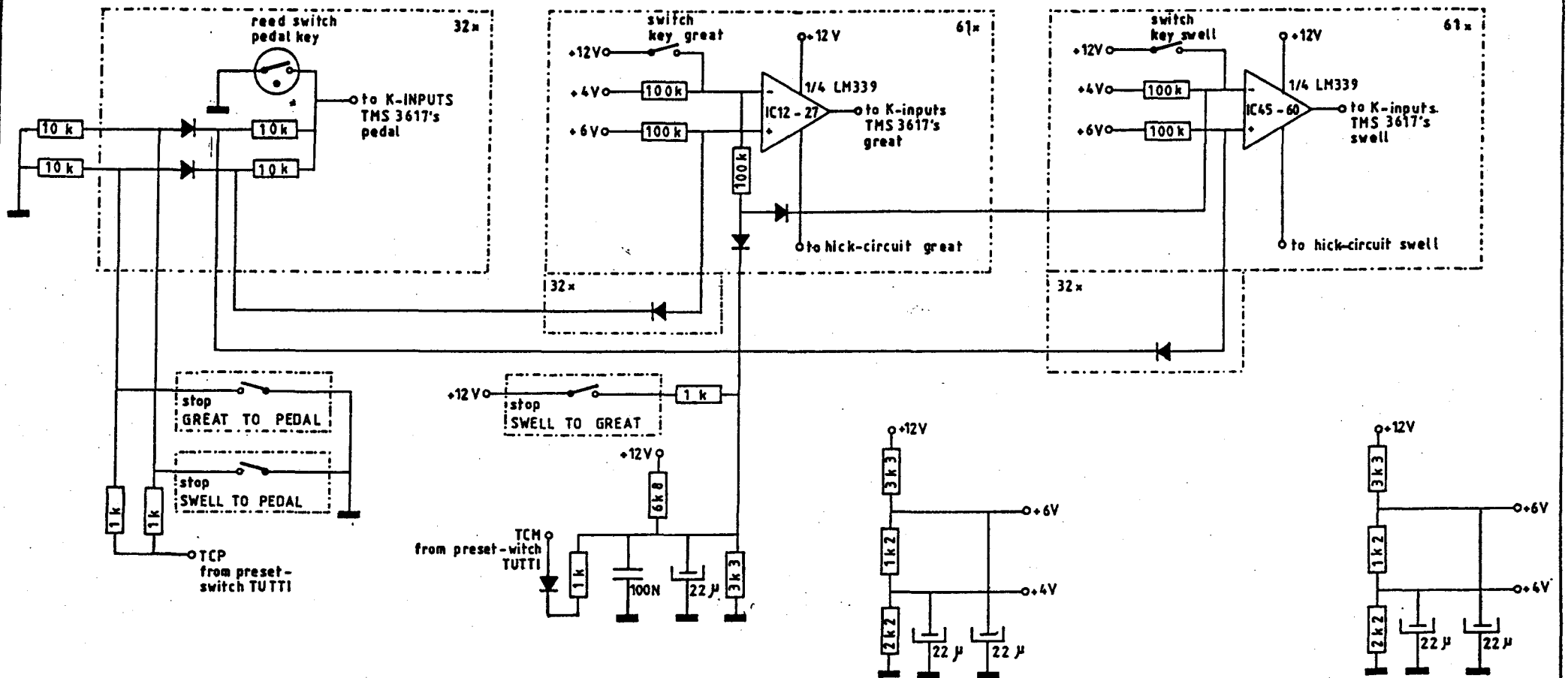

ALL DIODES: 1N4148

COUPLER CIRCUIT

Drawn	Date	Modified	Date	JOHANNUS ORGAN OPUS 250
Verschoer	19-02-86			
DESIGN				
LAB.				
copyright: ELECTRONIUM B.V.	JOHANNUS ORGELBOUW b.v.	morsestraat 28 6716 AH EDE HOLLAND Tel 08380-37403	page: 4	

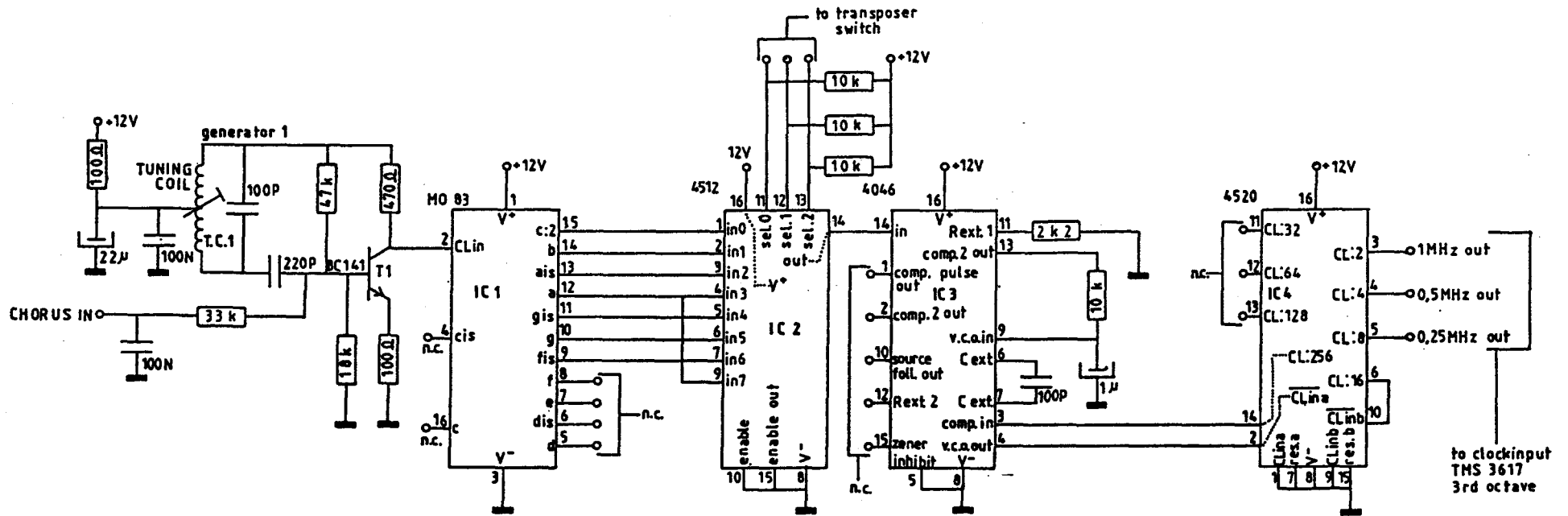
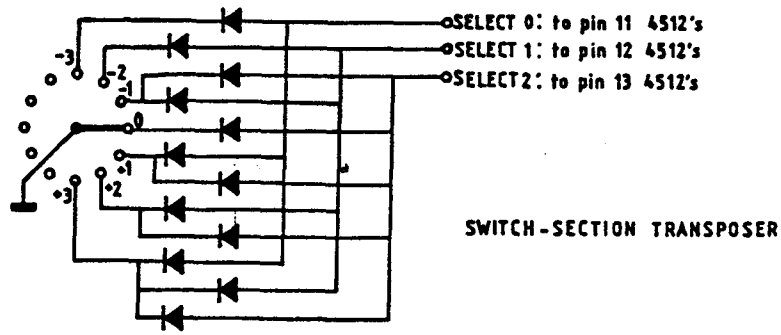

ALL DIODES: 1N 4148

SWITCH-SECTION TRANSPOSER &

GENERATOR/ TRANSPOSER PEDAL

Drawn	Date	Modified	Date
Verschoor	25-02-86		
DESIGN			
LAB			

**JOHANNUS
 ORGAN
 OPUS 250**

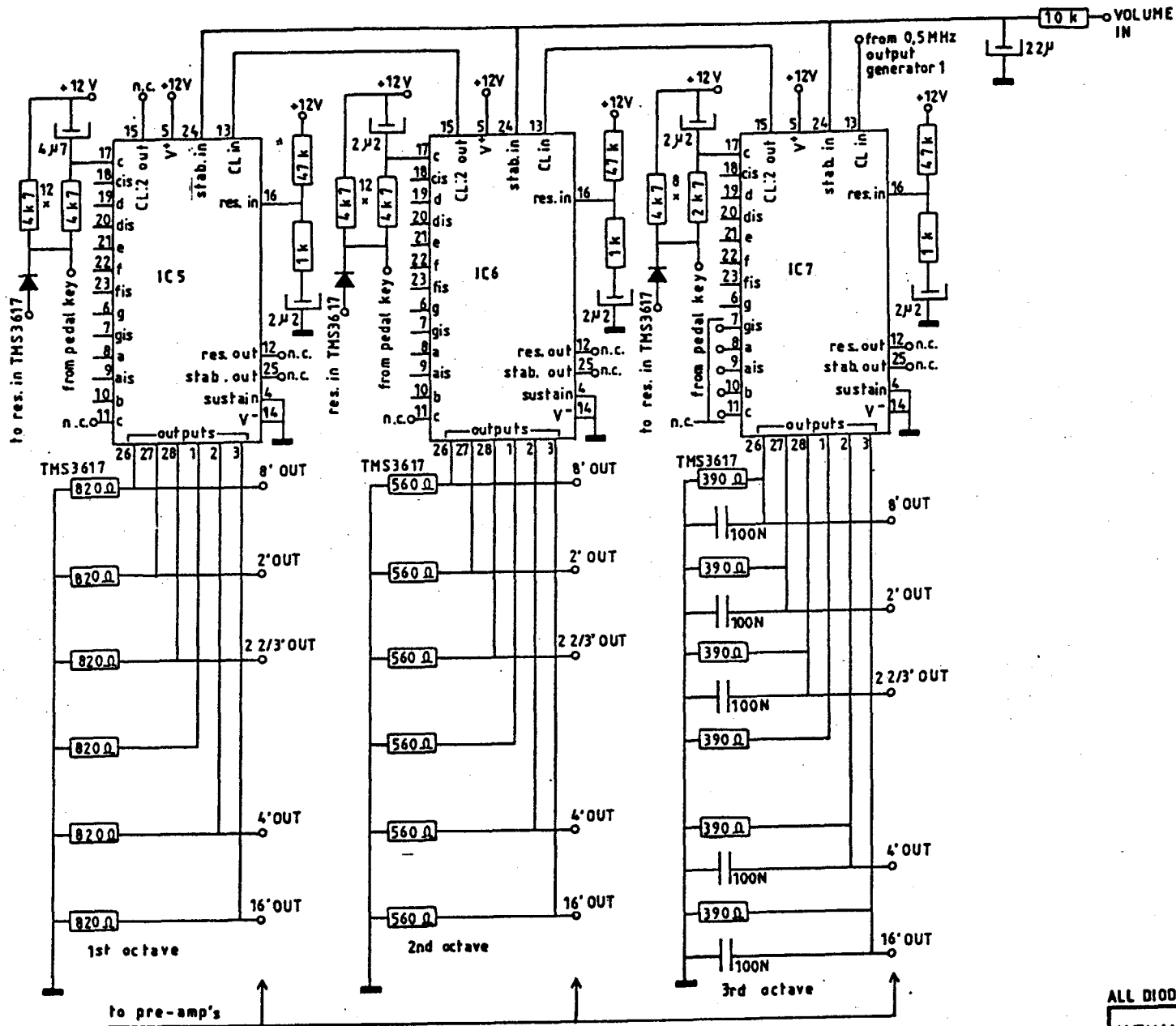

ALL DIODES: 1N4148

KEYING PEDAL

Drawn	Date	Modified	Date	JOHANNUS ORGAN OPUS 250
Verschoor	11-03-86			
DESIGN				
LAB.				
copyright: ELECTRONIUM B.V.	JOHANNUS ORGELBOUW b.v.	moraestraat 28 6716 AH EDE HOLLAND Tel. 06380-37403		page: 6

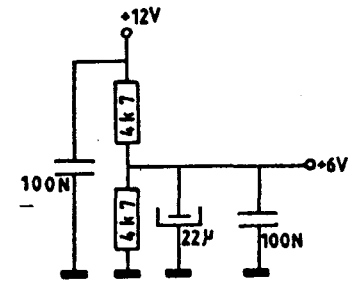
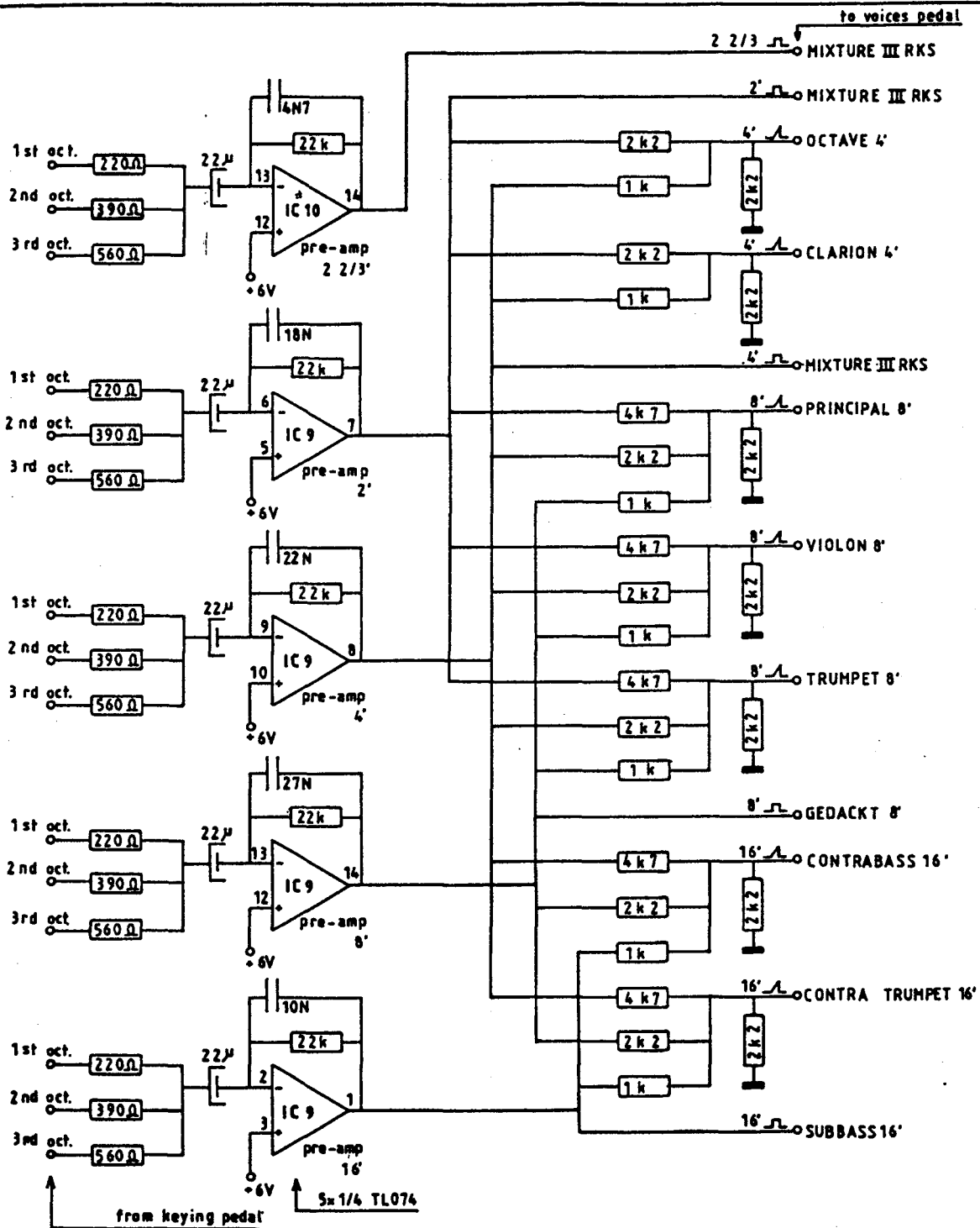

PRE - AMP'S PEDAL				JOHANNUS ORGAN OPUS 250
Drawn	Date	Modified	Date	
Verschoor	21-03-86			copyright: ELECTRONIUM B.V.
DESIGN				
LAB.				
copyright: ELECTRONIUM B.V.		JOHANNUS ORGELBOUW b.v.		morsestraat 28 6716 AH EDE HOLLAND Tel. 06380-37403
				page: 7

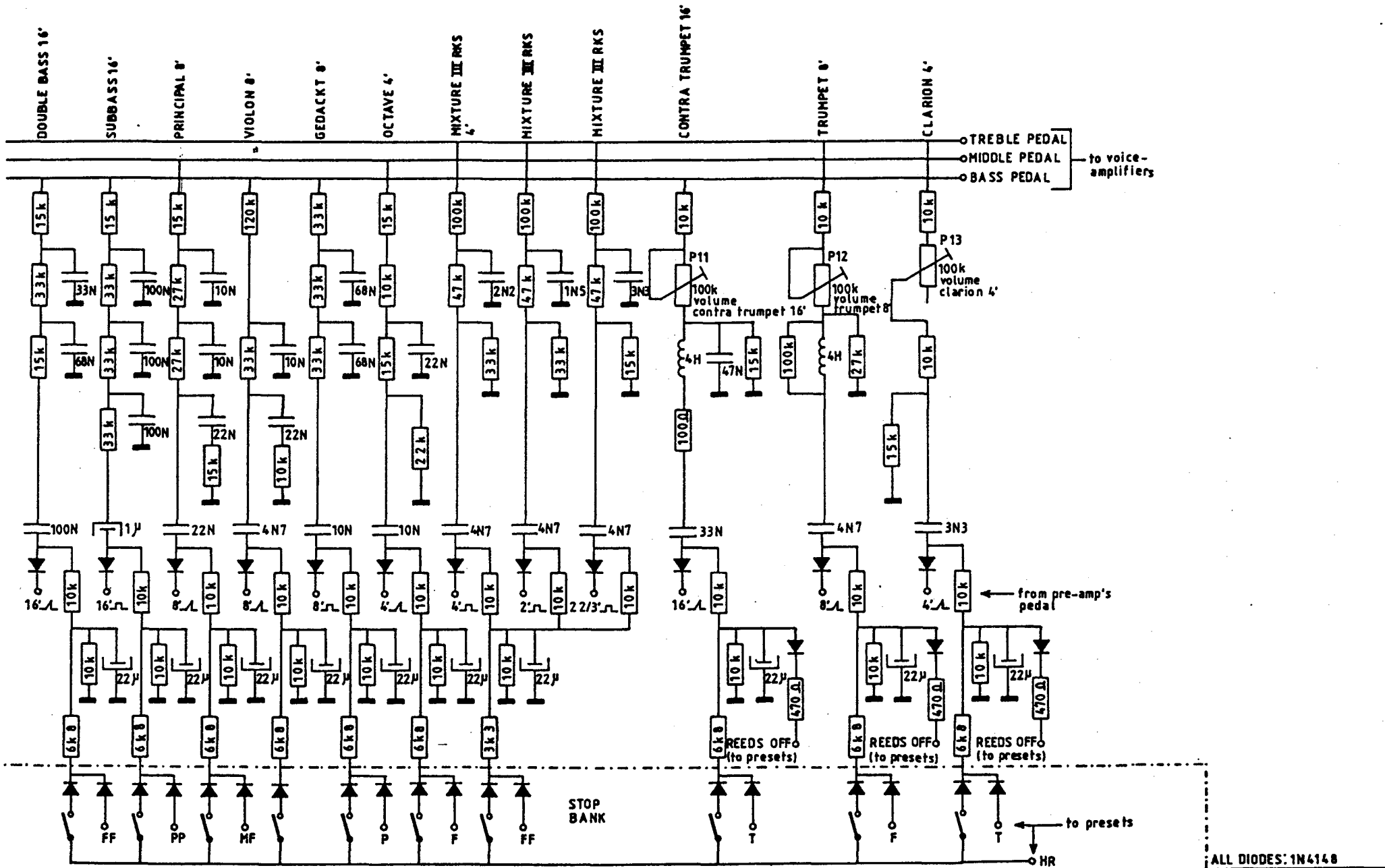

VOICES PEDAL				JOHANNUS ORGAN OPUS 250	
Drawn	Date	Modified	Date		
Verschoor	25-03-86			copyright: ELECTRONIUM B.V.	
DESIGN					
LAB.				JOHANNUS ORGELBOUW b.v.	
moraestraat 28 6716 AH EDE HOLLAND Tel. 08380-37403					
					page: 8

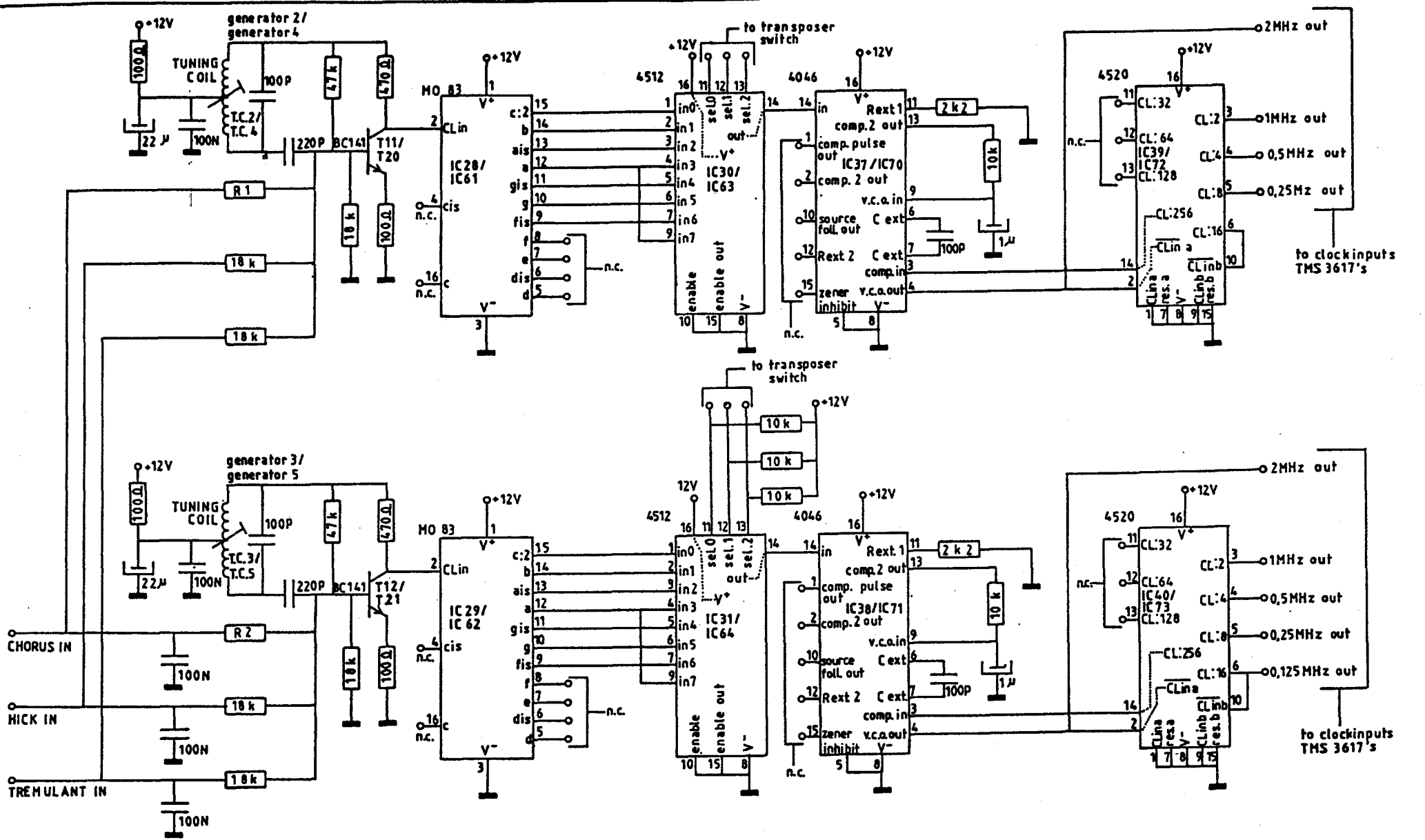

generator 2: R1=100k
 generator 4: R1=33k
 generator 3: R2= —
 generator 5: R2= 56k

GENERATORS / TRANSPOSERS MANUALS			
(1 x GREAT & 1 x SWELL)			
Drawn	Date	Modified	Date
Verschoor	25-02-86		
DESIGN			
LAB			
copyright:	JOHANNUS		morsestraat 28
ELECTRONIUM B.V.	ORGELBOUW b.v.		6716 AH EDE HOLLAND
			Tel. 06380-37403
			page: 9

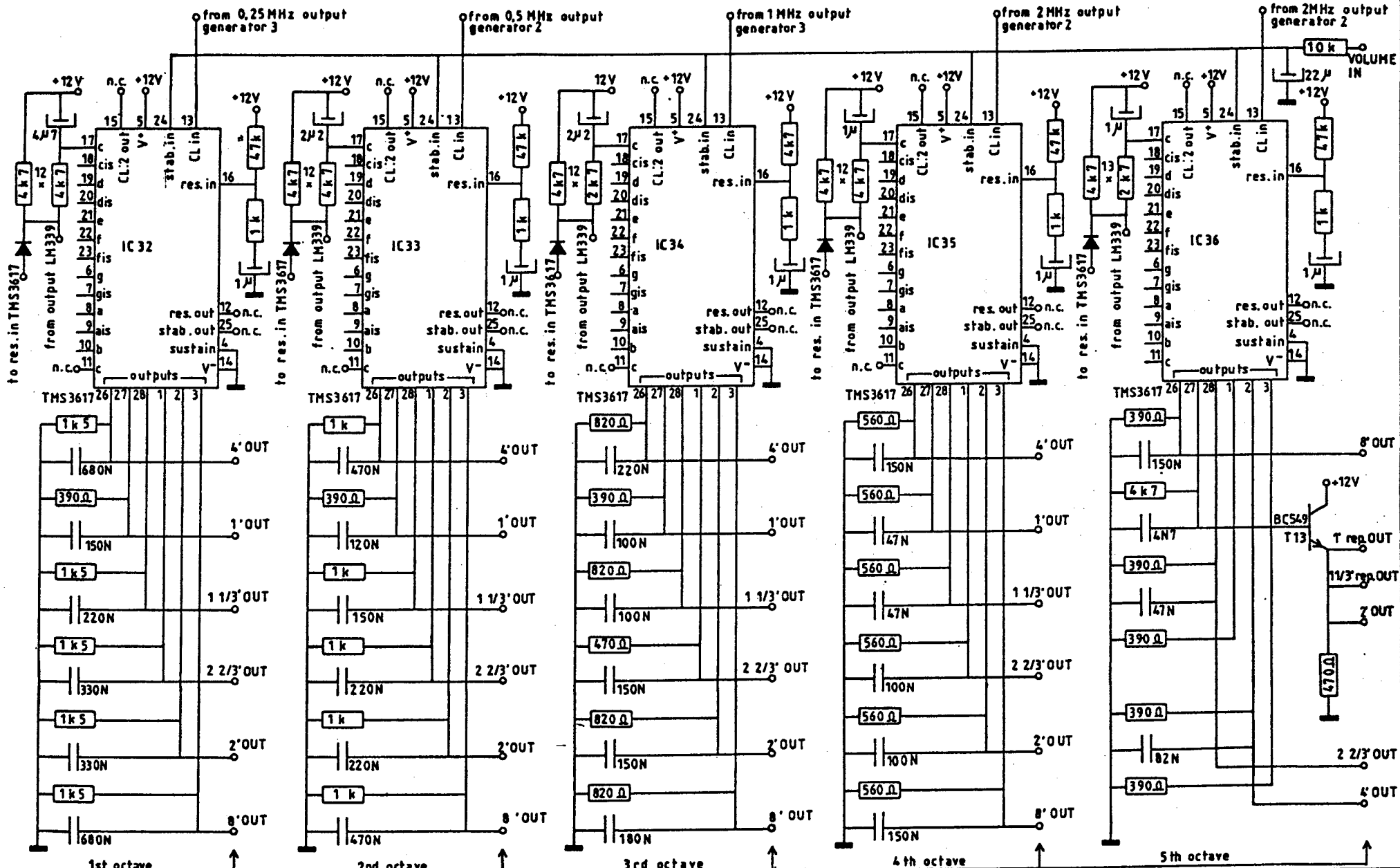

ALL DIODES: 1N 4148

KEYING GREAT

Drawn	Date	Modified	Date
Verschuur	06-03-86		
DESIGN			
LAB.			
copyright:		JOHANNUS	
ELECTRONIUM B.V.		ORGELBOUW b.v.	

**JOHANNUS
ORGAN
OPUS 250**

morsestraat 28
6716 AH EDE HOLLAND
Tel. 08380-37403

page:
10

to pre-amp's

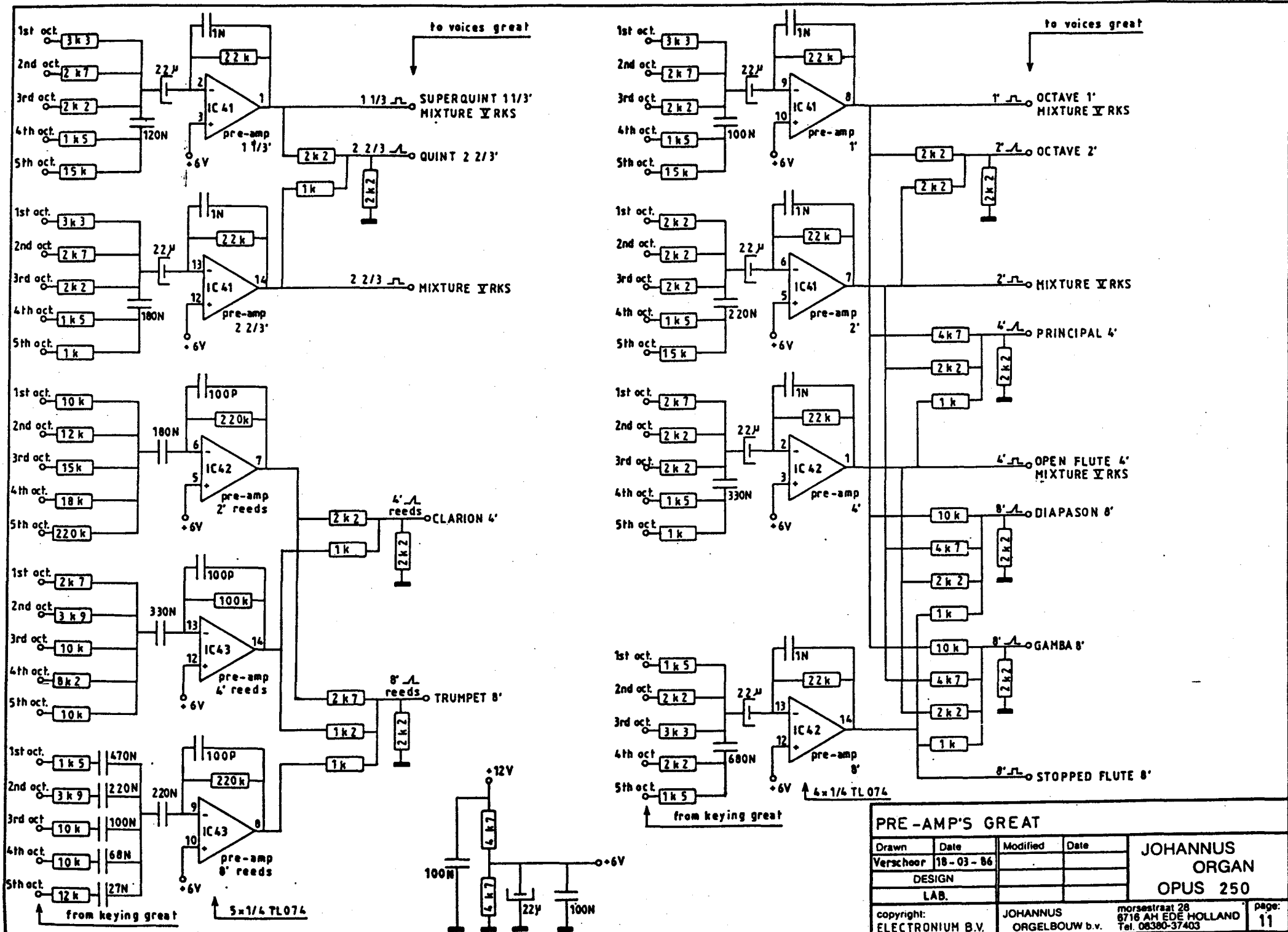

PRE-AMP'S GREAT

Drawn	Date	Modified	Date
Verschoor	18-03-86		
DESIGN			
LAB.			

**JOHANNUS
ORGAN
OPUS 250**

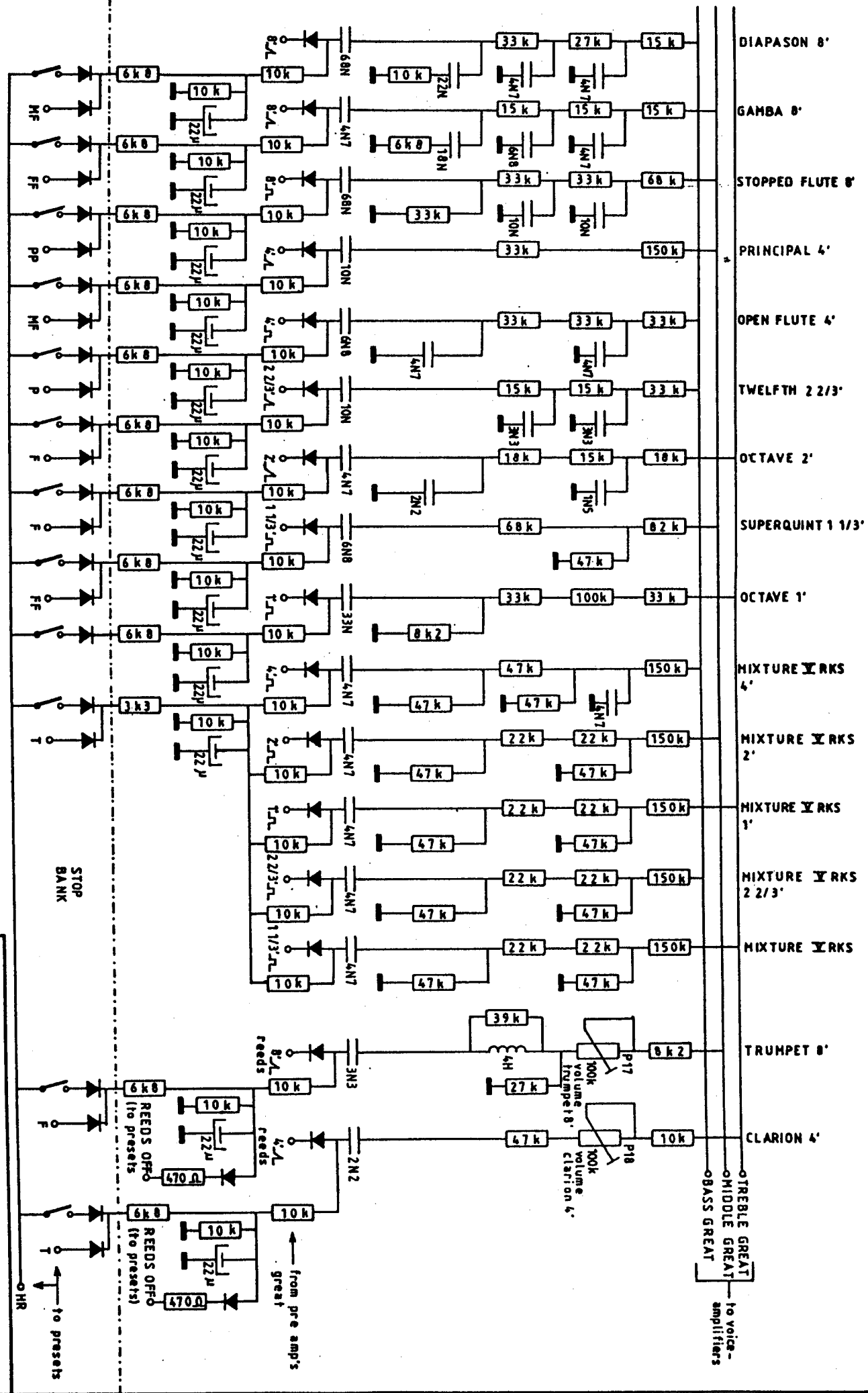

ALL DIODES: IN4148

VOICES GREAT

Drawn	Date	Modified	Date
Verschoor	25-03-86		
DESIGN			
LAB			

JOHANNUS ORGAN OPUS 250

copyright: JOHANNUS ORGELBOUW B.V.
 HOLLAND
 12

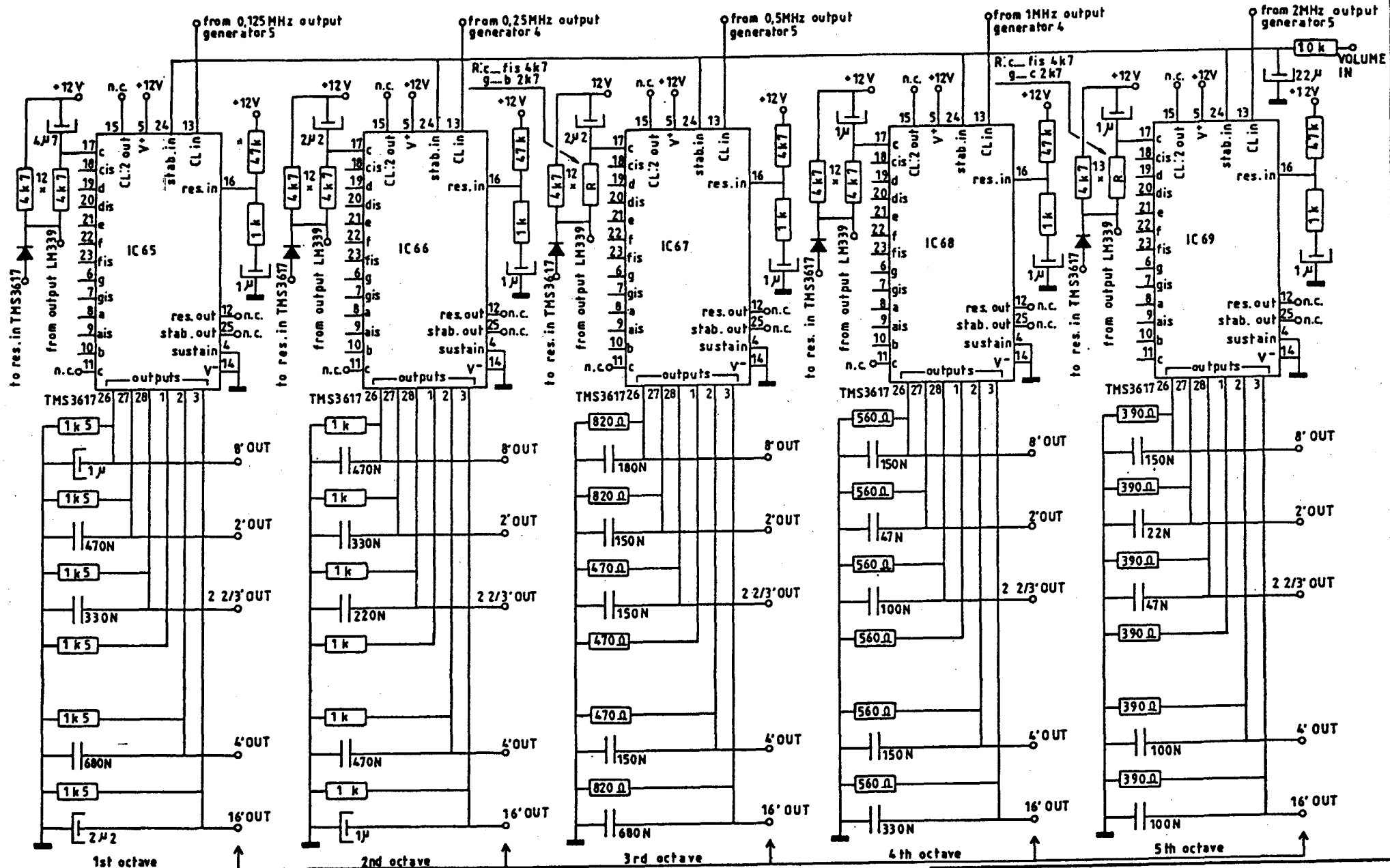

to pre-amp's

ALL DIODES: 1N4148

KEYING SWELL

Drawn	Date	Modified	Date
Verschoor	06-03-86		
DESIGN			
LAB.			

**JOHANNUS
ORGAN
OPUS 250**

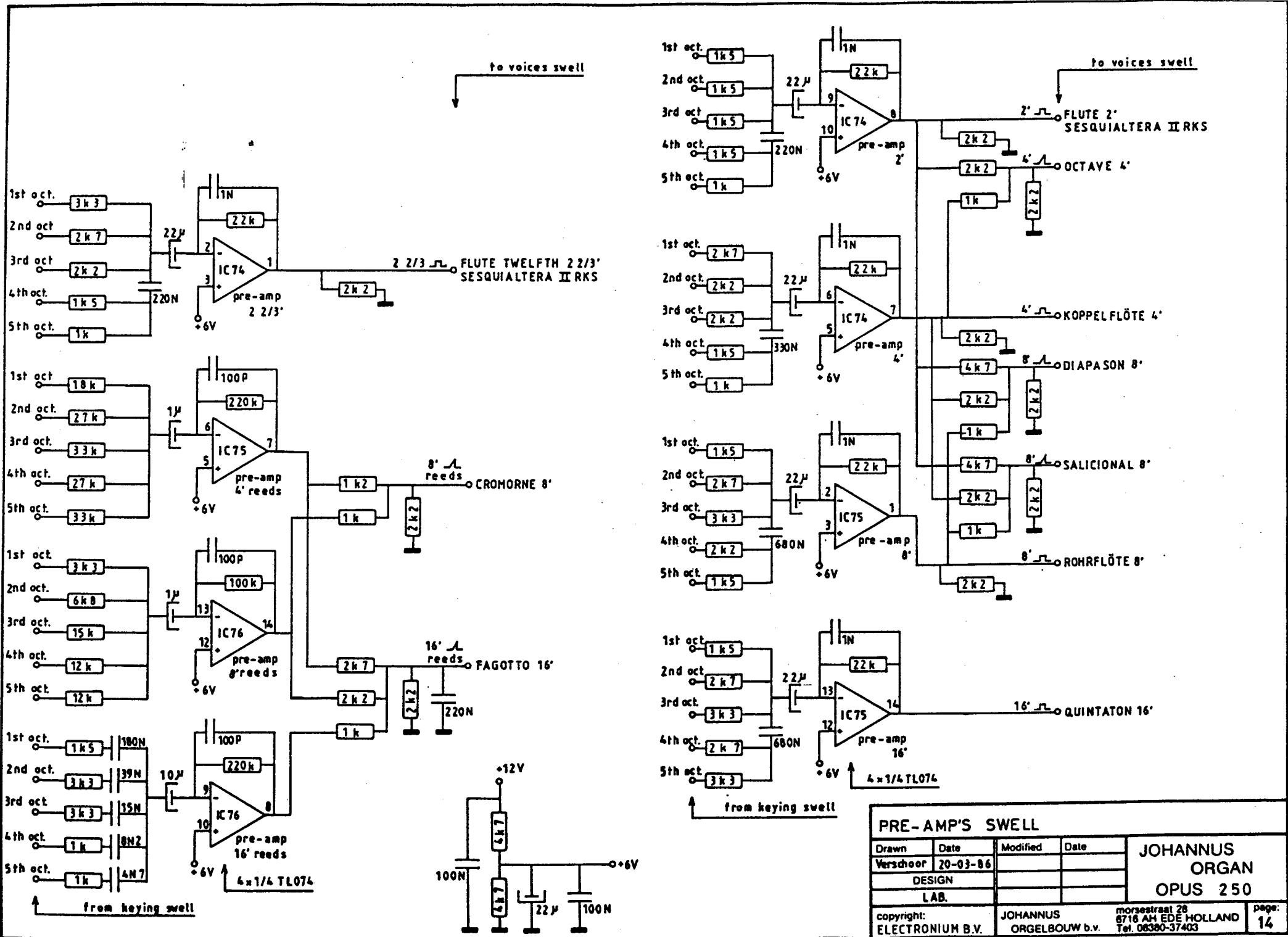

PRE-AMP'S SWELL			
Drawn	Date	Modified	Date
Verschoor	20-03-86		
DESIGN			
LAB.			
copyright:	JOHANNUS		morsestraat 28
ELECTRONIUM B.V.	ORGELBOUW b.v.		6716 AH EDE HOLLAND
			Tel. 08380-37403
			page: 14

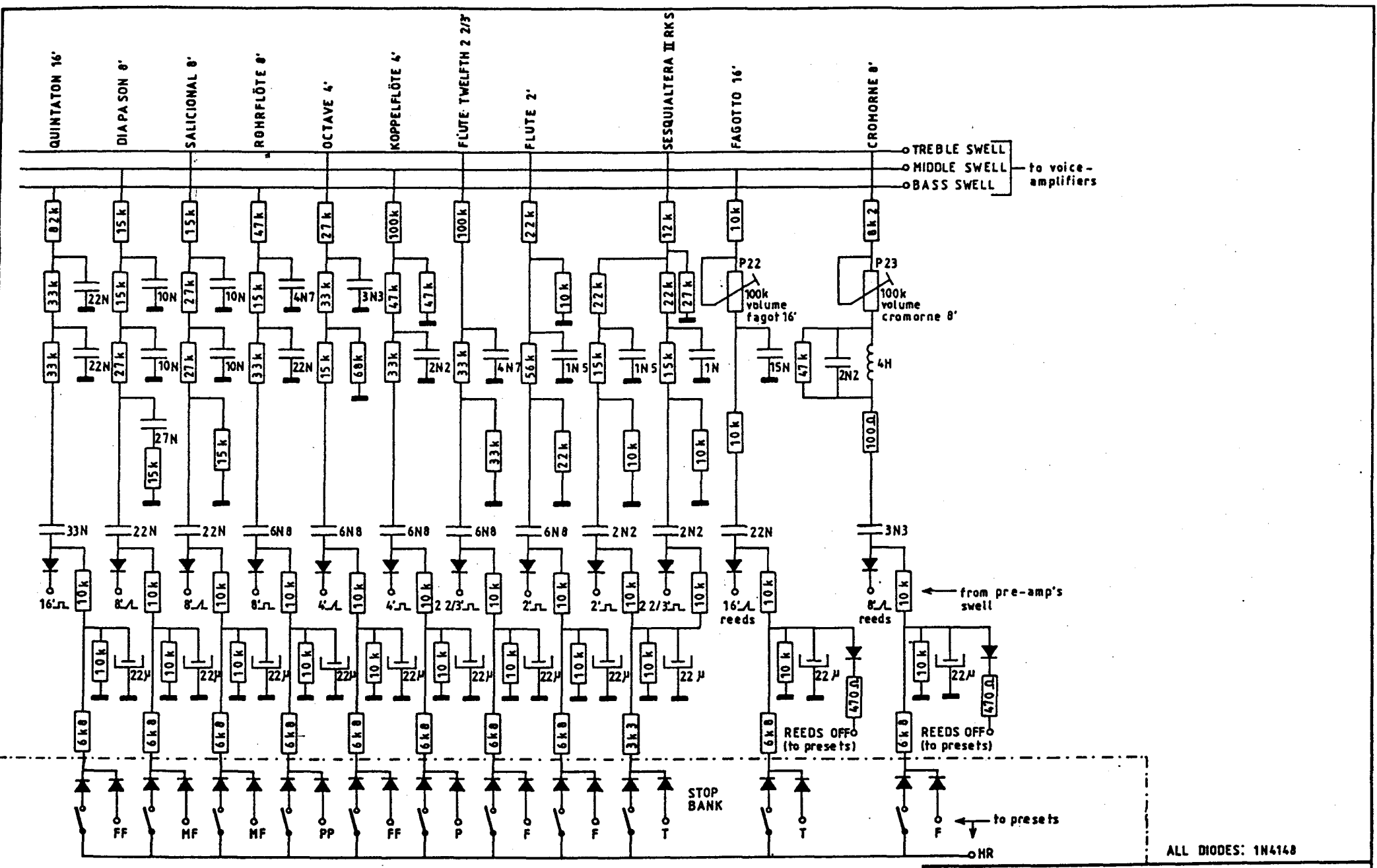

ALL DIODES: 1N4148

VOICES SWELL			
Drawn	Date	Modified	Date
Verschoor	24-03-86		
DESIGN			
LAB.			
copyright:	JOHANNUS	morsestraat 28	
ELECTRONIUM B.V.	ORGELBOUW b.v.	6716 AH EDE HOLLAND	
		Tel. 08380-37403	
		page:	15

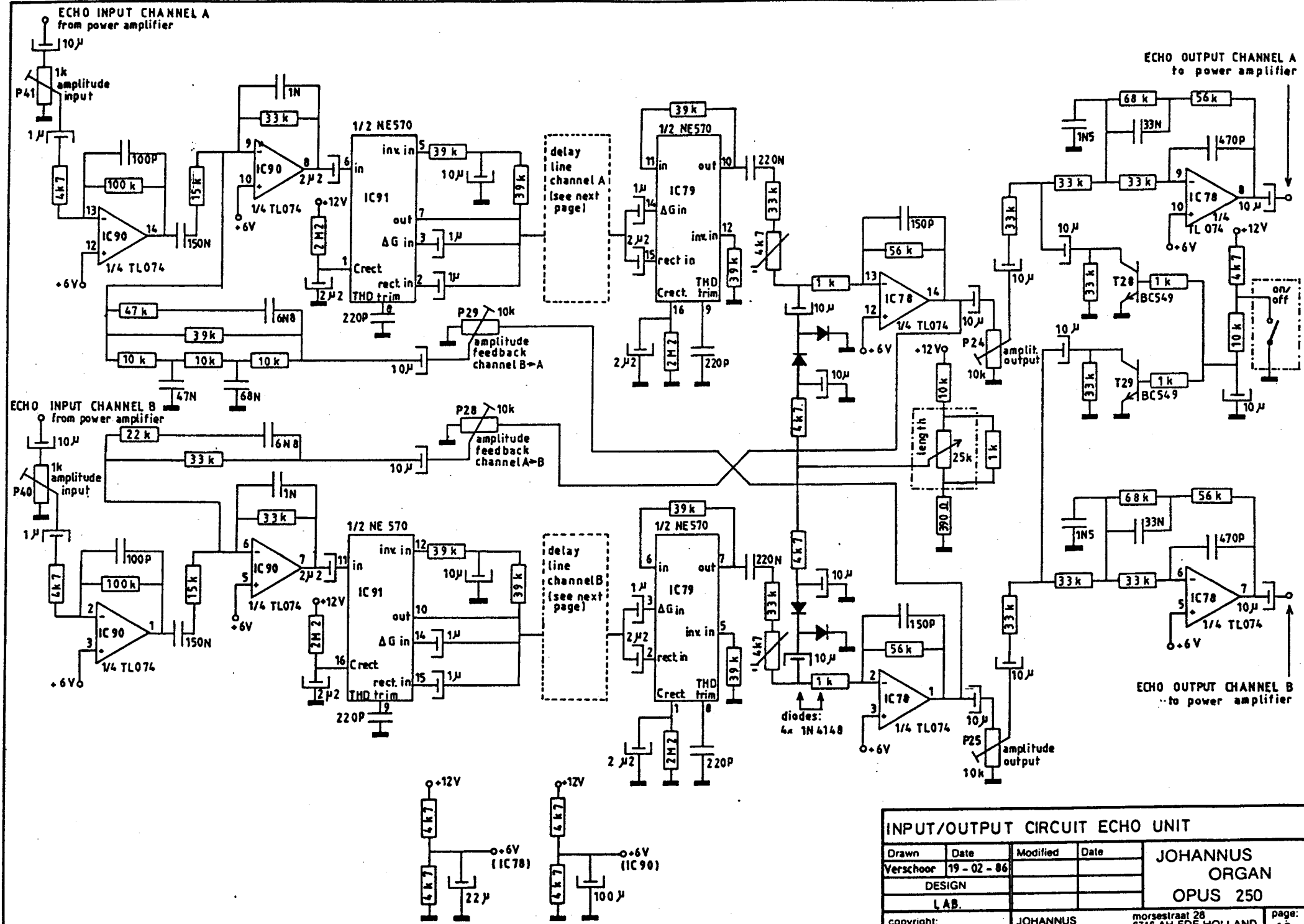

INPUT/OUTPUT CIRCUIT ECHO UNIT

Drawn	Date	Modified	Date	JOHANNUS ORGAN OPUS 250
Verschoor	19-02-86			
DESIGN				
LAB.				page: 16
copyright: ELECTRONIUM B.V.	JOHANNUS ORGELBOUW b.v.	morsestraat 28 6716 AH EDE HOLLAND Tel 08380-37403		

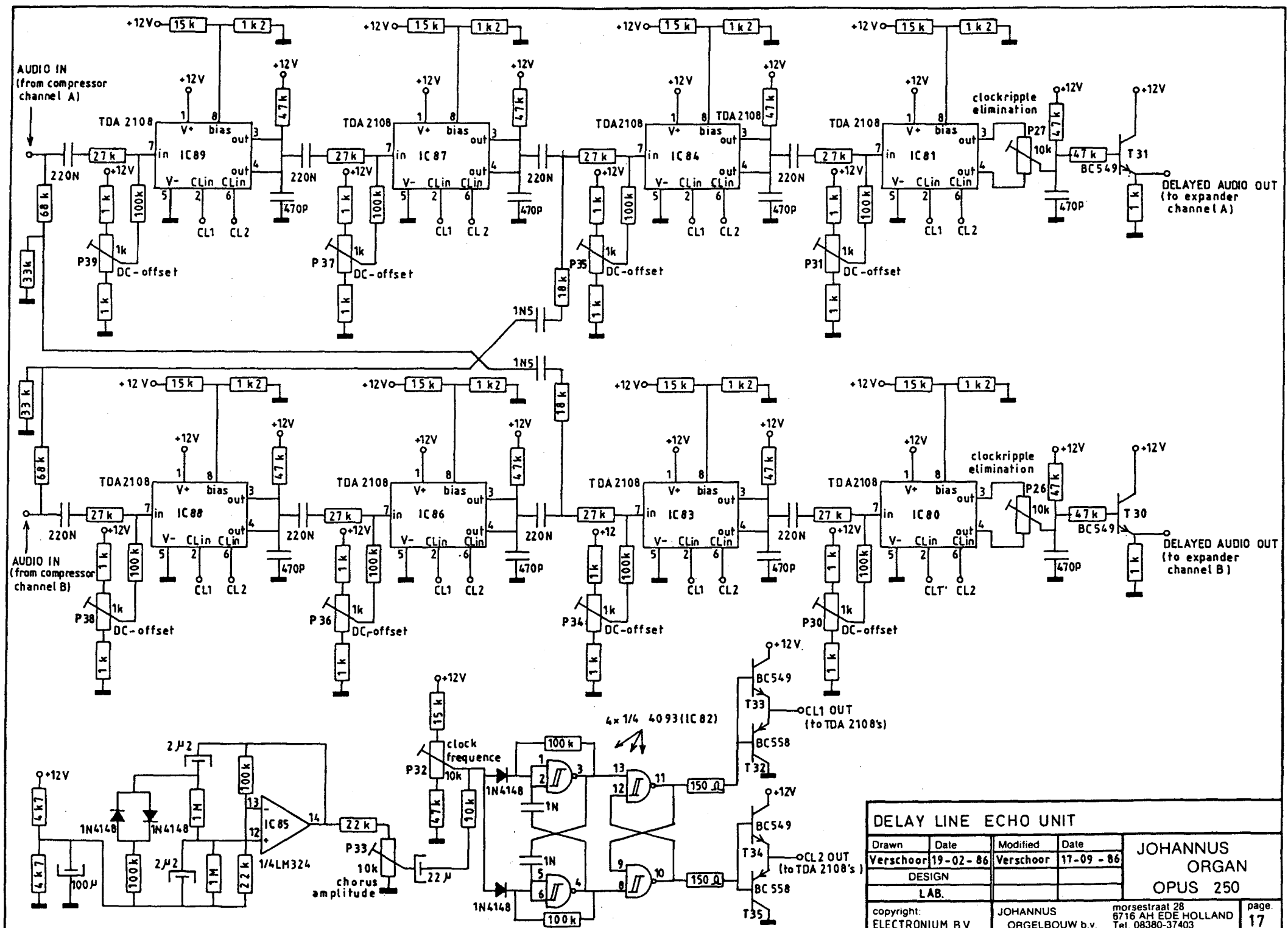

DELAY LINE ECHO UNIT				JOHANNUS ORGAN OPUS 250
Drawn	Date	Modified	Date	
Verschoor	19-02-86	Verschoor	17-09-86	
DESIGN				
LAB.				
copyright: ELECTRONIUM B.V.	JOHANNUS ORGELBOUW b.v.	morsestraat 28 6716 AH EDE, HOLLAND Tel. 08380-37403	page. 17	

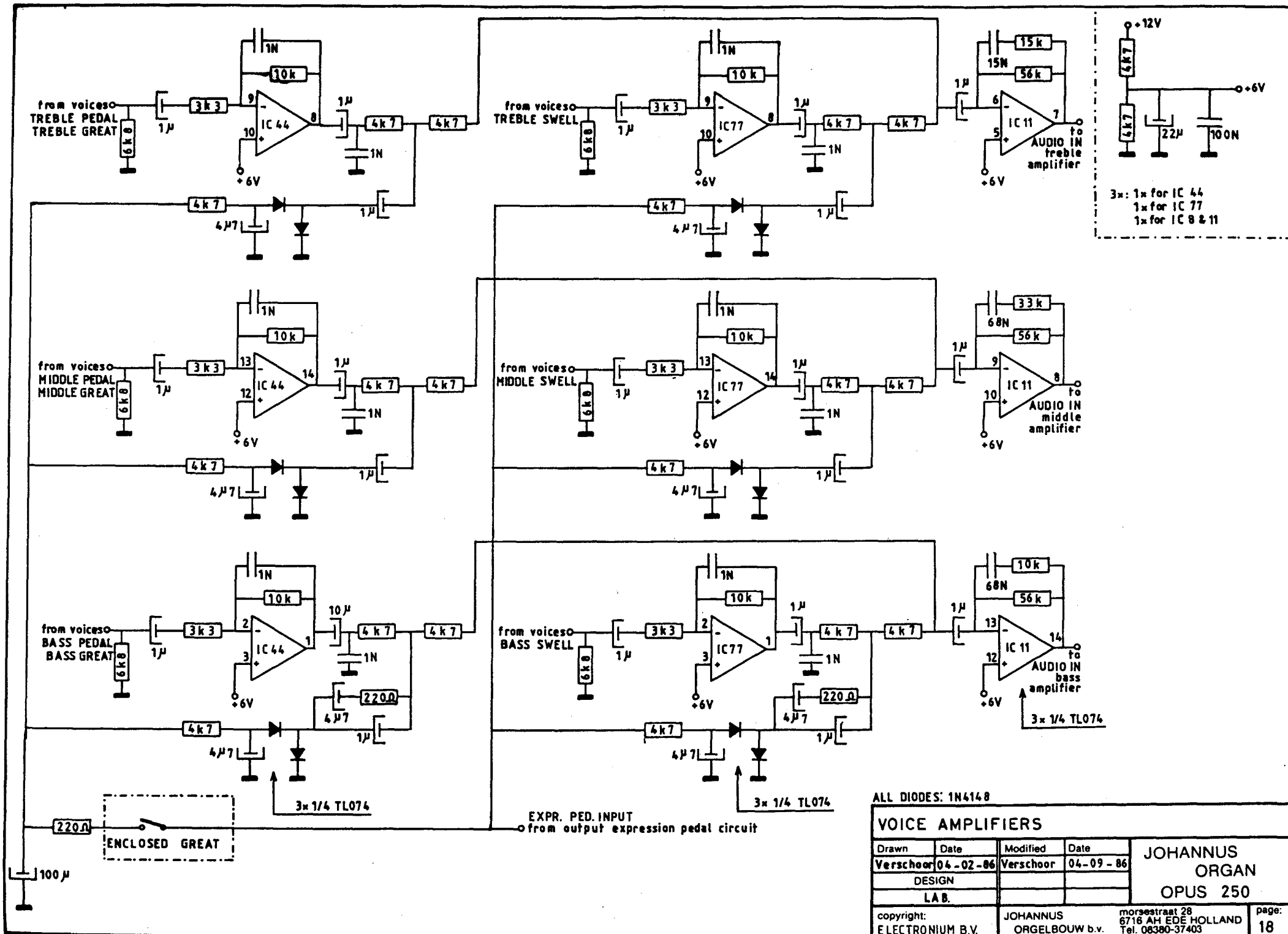

ALL DIODES: 1N4148

VOICE AMPLIFIERS

Drawn	Date	Modified	Date
Verschoor	04-02-86	Verschoor	04-09-86
DESIGN			
L.A.B.			
copyright:	JOHANNUS ORGELBOUW b.v.		
ELECTRONIUM B.V.	morsestraat 28 6716 AH EDE HOLLAND Tel. 08380-37403		

**JOHANNUS
ORGAN
OPUS 250**

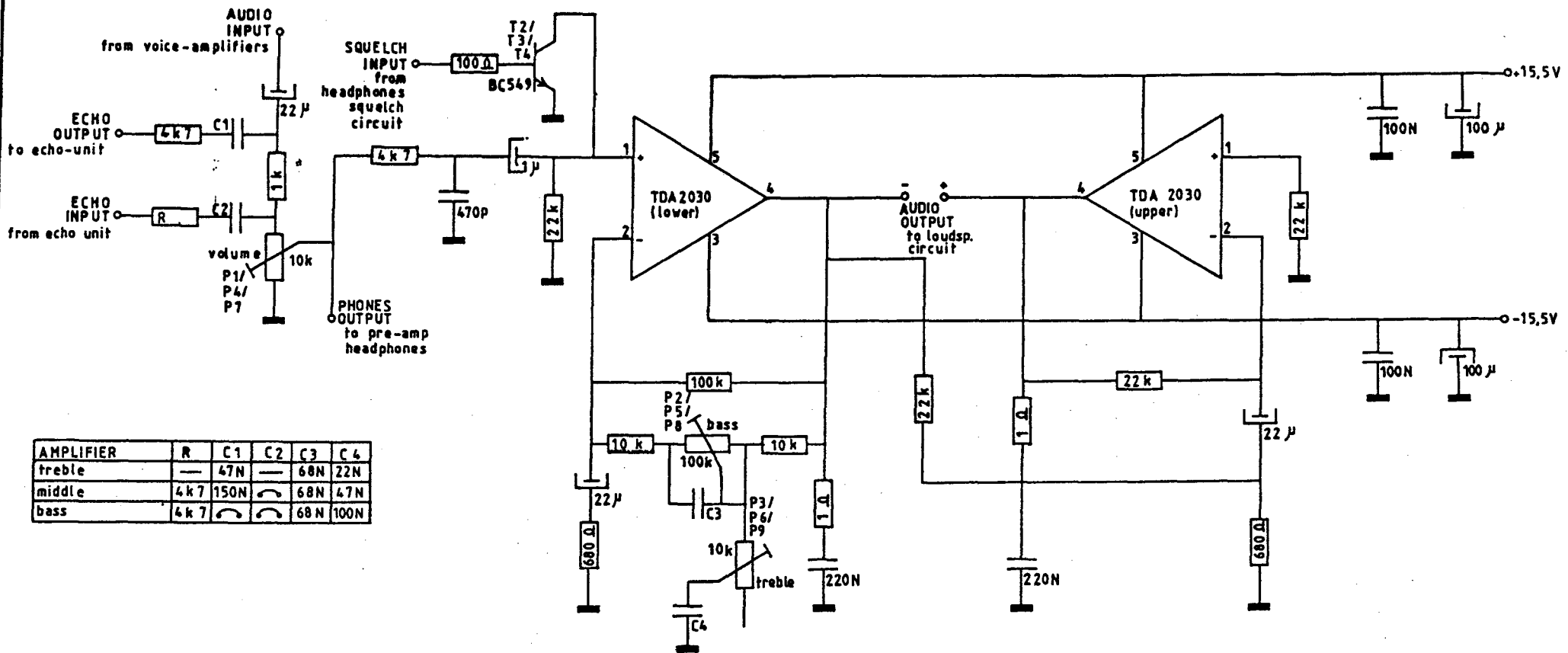

AMPLIFIER	R	C1	C2	C3	C4
treble	—	47N	—	68N	22N
middle	4k7	150N	—	68N	47N
bass	4k7	—	—	68N	100N

POWER - AMPLIFIER (3 x)

Drawn	Date	Modified	Date	JOHANNUS ORGAN OPUS 250
Verschoor	19-02-86			
DESIGN				
LAB				
copyright: ELECTRONIUM B.V.	JOHANNUS ORGELBOUW b.v.	morsestraat 28 6716 AH EDE HOLLAND Tel. 08380-37403		page: 19

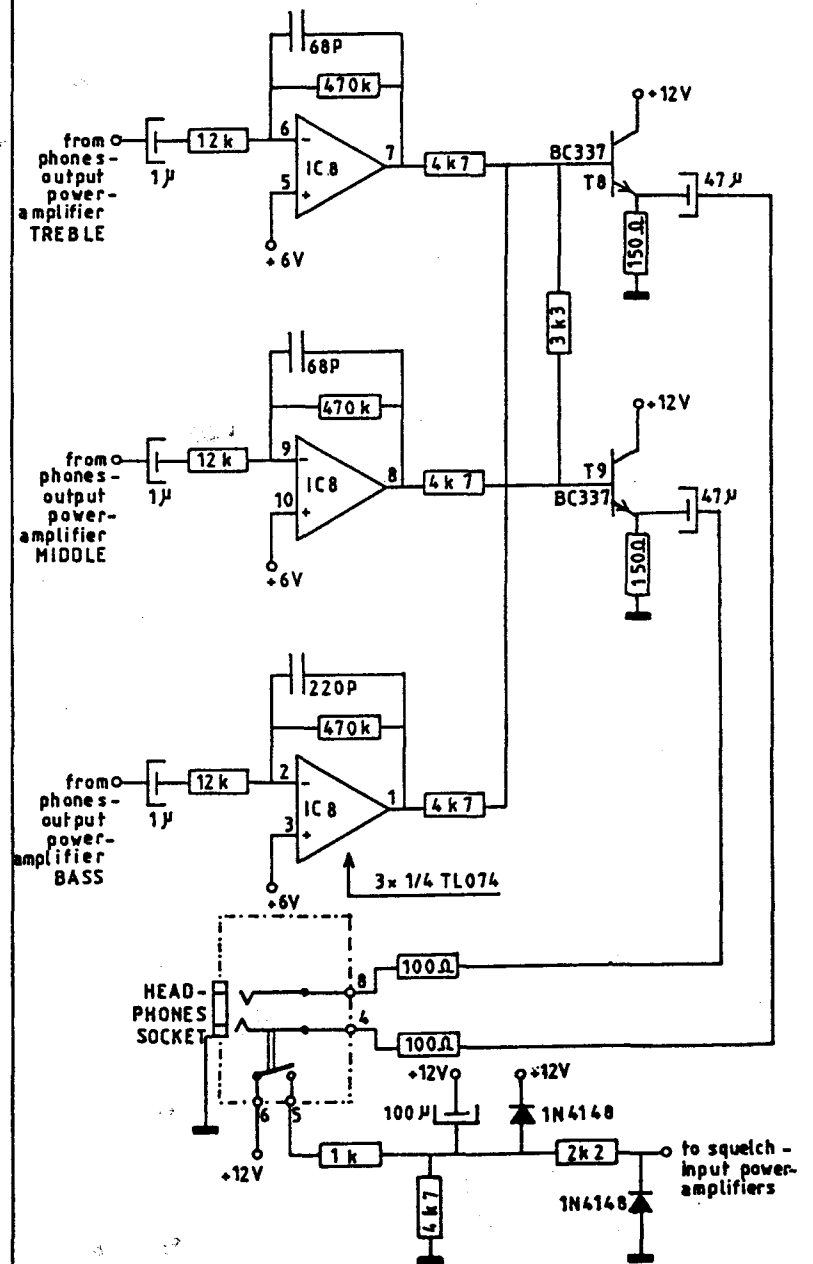
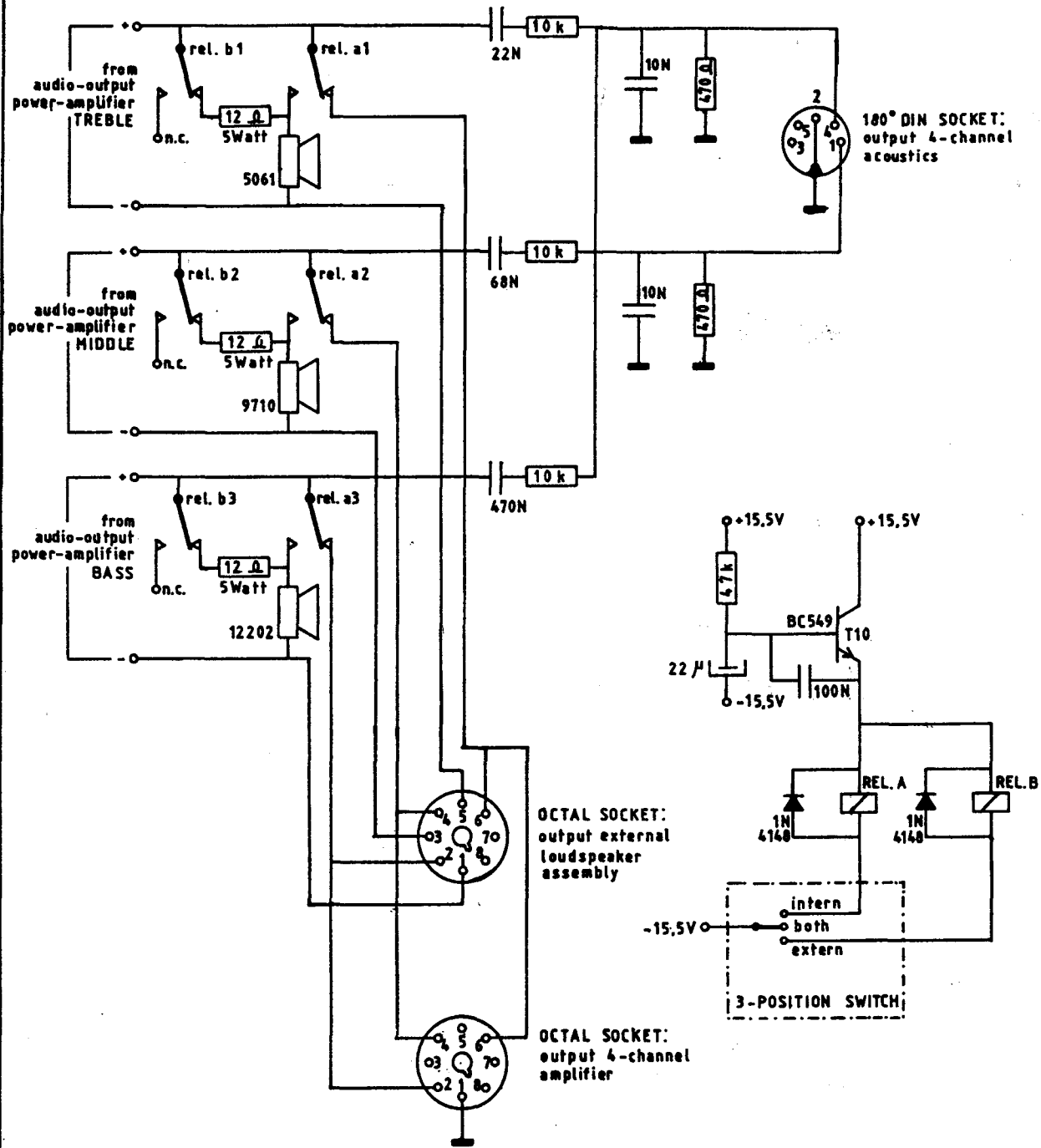

LOUDSPEAKER - & HEADPHONES - CIRCUIT

Drawn	Date	Modified	Date	JOHANNUS ORGAN OPUS 250
Verschuur	01-05-86			
DESIGN				
LAB.				
copyright:	ELCTRONIUM B.V.	JOHANNUS ORGELBOUW b.v.	morsestraat 28 8716 AH EDE HOLLAND Tel. 08380-37403	page: 20

A K
W4148

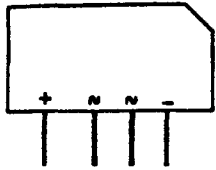

B80 C5000/3300



μA 7812

μA 7818

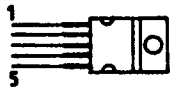
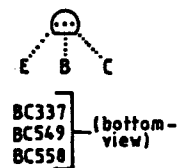
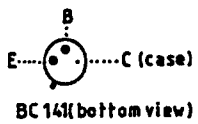

1=non-inverting input
2=inverting input
3=V⁻
4=output
5=V⁺

TDA 2030

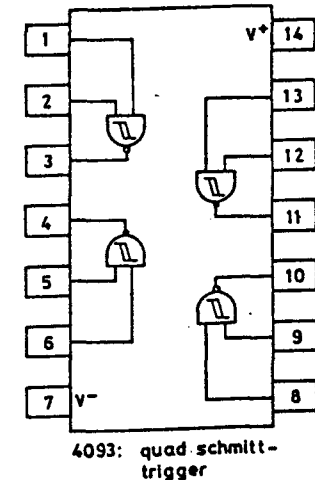
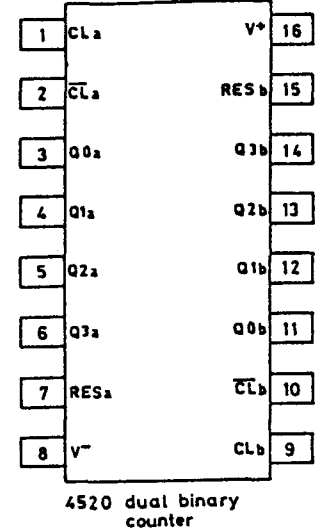
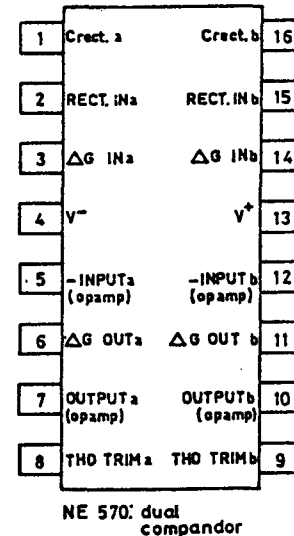
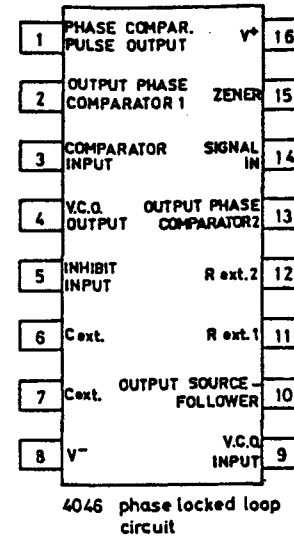
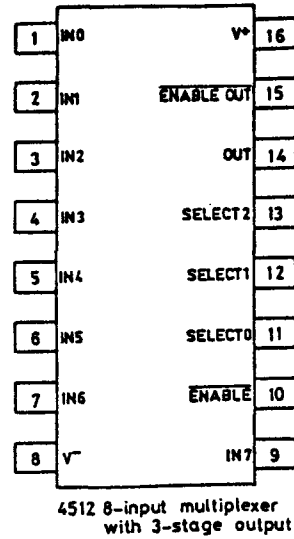
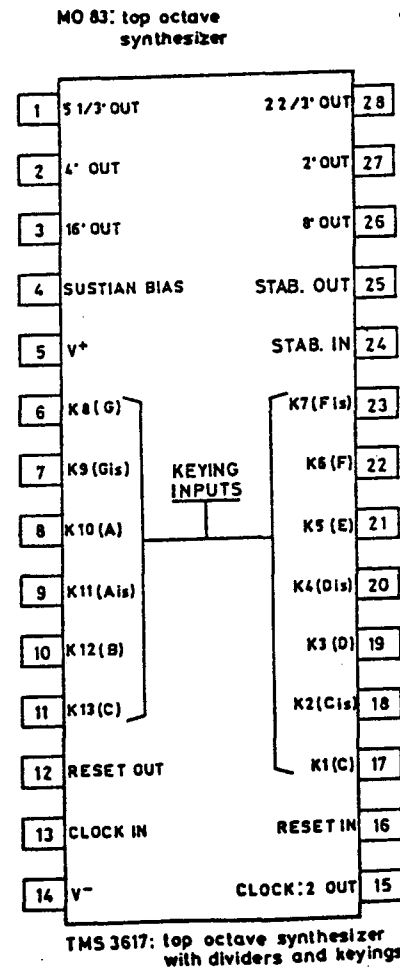
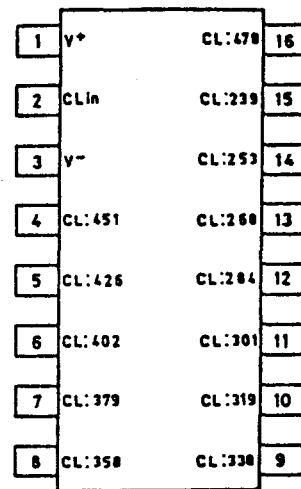
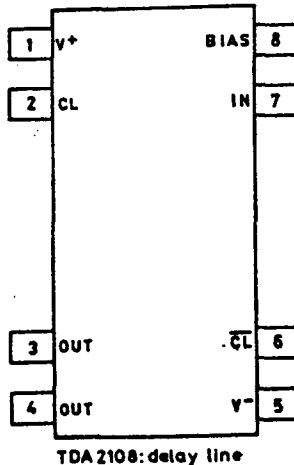
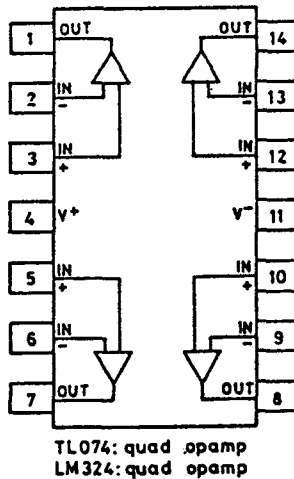
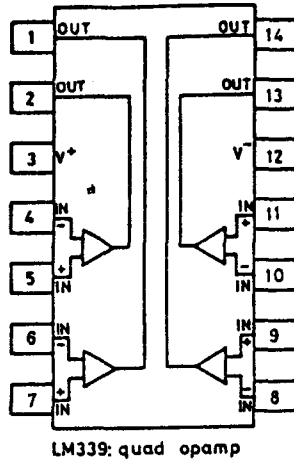

GENERAL INFORMATION SEMI-CONDUCTORS			
Drawn	Date	Modified	Date
Verschoor	07-04-86		
DESIGN			
copyright:		JOHANNUS	
ELECTRONIUM B.V.		ORGELBOUW b.v.	
		morsestraat 28 8716 AH EDE HOLLAND Tel. 08380-37403	
			page: 21